



ISO Cylinders

Wide range and fast delivery



WIDE RANGE: Our ISO Cylinders take standardisation to another level

SMC presents you our full range of standards-complying cylinders: tie-rod, compact and round crimped body cylinders which observe standards ISO 15552, ISO 6431, ISO 21287 and ISO 6432 respectively.

Nevertheless, in SMC, standard does not mean basic and we provide our ISO standard cylinders with additional features so they can adapt to your more particular demands:

- Wide range of mounting accessories – It is possible to mount the cylinders practically everywhere
- Many options available as standard: ATEX compliant to be used in potentially explosive atmospheres, high and low temperature resistance or intermediate strokes, among others (detailed information in the inside). **Because the applications are not always standard.**

FAST DELIVERY: SMC is close to you with ISO

Close to you with Standard ISO - Immediate Shipping & Fast Delivery -
At our European Central Warehouse placed in Antwerp we stock more than 1300 standard ISO Cylinder references (detailed information in the inside).

Close to you with Semi-customised ISO - Production time: from 3 to 5 days* -
Our newly opened Czech Republic Factory counts with the most modern facilities and highly qualified personnel to adapt our ISO range to your requirements (detailed information in the inside).

Close to you with Customised ISO - Production time: from 1 to 6 days* -
If you require a fully customised ISO, SMC's local facilities will adapt any of our ISO range to your specific demands (detailed information in the inside).

SMC's ISO Range – a Quick view

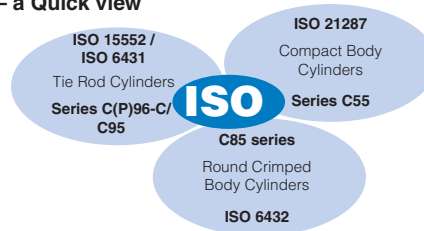

ISO 15552– C96-C & CP96-C Series – ISO 6431 – C95 Series – Profile & Round Tube Tie-Rod Cylinder The ISO cylinder with more standard options

With an easy adjustment of the cushion valve and a maximum flexibility for auto switch mounting on all four sides, C(P)96-C-C95 series achieve the best performance for both standard and specific applications. It can even be used in extreme environments or special conditions, for example: in smooth movements at low pressure, explosive atmospheres, places at high or low temperatures, dusty environments and areas subject to water splashing, among others.

ISO 21287 – C55 Series – Compact Body cylinder When space is a problem

If you don't find any cylinder that fits in that small place, C55 series is your solution. Designed in bores from Ø 20 to Ø 100, it now offers an improved and flush auto switch mounting possibilities with slide in grooves which can accommodate auto switches on all four cylinder sides without the need for auto switch brackets. There is also an option for explosive atmosphere.

ISO 6432 – C85 Series – Round Crimped Body cylinder A clean profile for dusty environments

The lightweight C85 has a unique rod packing design that prevents the entry of dust and its effectiveness of the seal is such that it is suitable for use in dusty environments, regardless of whether the environments are at high or low temperatures, or if you need to move slowly or work in explosive atmospheres.

* depending on model and quantity

ISO Cylinder, Series Variations and Index

	Series	Type	Action	Bore size [mm]														Standard stroke	Maximum stroke	Page					
				8	10	12	16	20	25	32	40	50	63	80	100	125	160				200	250			
ISO 15552 Tie-Rod Cylinder	CP96-C	Standard	Double acting, Single rod								•	•	•	•	•	•	•*				Up to 800 mm	Up to 2000 mm	4		
			Double acting, Double rod										•	•	•	•	•	•	•*					Up to 800 mm	Up to 2000 mm
		Non-Rotating	Double acting, Single rod										•	•	•	•	•	•						Up to 800 mm	Up to 800 mm
			Double acting, Double rod										•	•	•	•	•	•						Up to 800 mm	Up to 800 mm
	C96-C	Standard	Double acting, Single rod									•	•	•	•	•	•	•*				Up to 800 mm		Up to 1900 mm	
			Double acting, Double rod									•	•	•	•	•	•	•*				Up to 800 mm		Up to 1900 mm	
		Non-Rotating	Double acting, Single rod									•	•	•	•	•	•					Up to 800 mm		Up to 800 mm	
			Double acting, Double rod									•	•	•	•	•	•					Up to 800 mm		Up to 800 mm	
	Smooth	Double acting, Single rod										•	•	•	•	•	•	•*				Up to 800 mm	Up to 1000 mm		
		Double acting, Double rod										•	•	•	•	•	•					Up to 800 mm	Up to 1000 mm		
	55-CP96 (ATEX)	Standard	Double acting, Single rod									•	•	•	•	•	•	•				Up to 800 mm	Up to 2000 mm	6	
			Double acting, Double rod									•	•	•	•	•	•	•				Up to 800 mm	Up to 1000 mm		
		Non-Rotating	Double acting, Single rod									•	•	•	•	•	•					Up to 800 mm	Up to 800 mm		
			Double acting, Double rod									•	•	•	•	•	•					Up to 800 mm	Up to 800 mm		
	55-C96 (ATEX)	Standard	Double acting, Single rod									•	•	•	•	•	•	•				Up to 800 mm	Up to 2000 mm		
			Double acting, Double rod									•	•	•	•	•	•	•				Up to 800 mm	Up to 1000 mm		
Non-Rotating		Double acting, Single rod									•	•	•	•	•	•					Up to 800 mm	Up to 800 mm			
		Double acting, Double rod									•	•	•	•	•	•					Up to 800 mm	Up to 800 mm			
Smooth	Double acting, Single rod										•	•	•	•	•	•					Up to 800 mm	Up to 1000 mm			
	Double acting, Double rod										•	•	•	•	•	•					Up to 800 mm	Up to 1000 mm			
CP96-C and C96-C - Related products																			7						
ISO 6431 Tie-Rod Cylinder	C95	Standard	Double acting, Single rod																		—	Up to 2400 mm	8		
	55-C95 (ATEX)																				•	•		•	
C95 - Related products																			9						
ISO 6432 Round Crimped Body cylinder	C85	Standard	Double acting, Single rod	•	•	•	•	•	•												Up to 300 mm	Up to 1000 mm	10		
			Double acting, Double rod	•	•	•	•	•	•													Up to 300 mm		Up to 500 mm	
			Single acting, Single rod	•	•	•	•	•	•													Up to 150 mm		Up to 150 mm	
		Non-Rotating	Double acting, Single rod	•	•	•	•	•	•													Up to 300 mm		Up to 1000 mm	
			Single acting, Single rod	•	•	•	•	•	•													Up to 150 mm		Up to 150 mm	
			Double acting, Single rod	•	•	•	•	•	•													Up to 160 mm		Up to 1000 mm	
	55-C85 (ATEX)	Standard	Double acting, Single rod	•	•	•	•	•	•													Up to 300 mm	Up to 1000 mm	12	
			Double acting, Double rod	•	•	•	•	•	•													Up to 300 mm	Up to 500 mm		
		Non-Rotating	Double acting, Single rod	•	•	•	•	•	•													Up to 300 mm	Up to 1000 mm		
			Double acting, Double rod	•	•	•	•	•	•													Up to 300 mm	Up to 1000 mm		
C85 - Related products																			13						
ISO 21287 Compact cylinder	C55	Standard	Double acting, Single rod					•	•	•	•	•	•	•	•	•					Up to 150 mm	Up to 150 mm	14		
	55-C55 (ATEX)																						15		
	C55 - Related products																			16					
Related products																			17						
Other non-ISO cylinders																			18						

* Available for series C96 and CP96 only.



ISO Standard [ISO 15552]. Tie rod cylinder
Standard / Non Rotating / Smooth type
Double Acting, Single/Double Rod
Series C(P)96-C
Ø 32, Ø 40, Ø 50, Ø 63, Ø 80, Ø 100

- Light weight
- Easy and fine adjustment of the air cushion valve
- Integrated function of the air cushion and the bumper
- Minimum piston rod deflection
- Wide range of made to order specifications
- Strokes up to 2000 mm
- Operating piston speed up to 1000 mm/s
- ATEX compliant version for explosive atmospheres
- Possible to mount directly round D-M9□ auto switches on the 4 surfaces of the CP96-C

Standard Double Acting Single rod

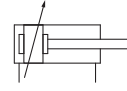

Standard Double Acting Double rod

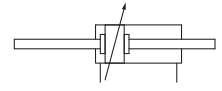

Non-rotating Double Acting Single rod

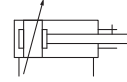

Non-rotating Double Acting Double rod

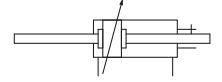

Smooth cylinder Double Acting Single rod

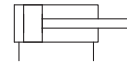

How to Order

Profile cylinder

CP96 S D B 32 - 100 C

Round tube cylinder

C96 S D B 32 - 100 C

Type

S	Standard
K	Non-rotating rod
Y ^{Note)}	Smooth cylinder

Note) For C96-C only

Built-in magnet

Mounting

B	Basic/Without bracket
T ^{Note)}	Centre trunnion

Note) For C96-C only

Bore size

32	32 mm
40	40 mm
50	50 mm
63	63 mm
80	80 mm
100	100 mm
125 ^{Note)}	125 mm

Note) For C(P)96 only

Stroke

Bore size [mm]	Standard stroke [mm]	Single rod		Double rod		C(P)96K ^{Note)} Max. stroke	C96Y ^{Note)} Max. stroke
		CP96 ^{Note)} Max. stroke	C96 ^{Note)} Max. stroke	CP96 ^{Note)} Max. stroke	C96 ^{Note)} Max. stroke		
32	25, 50, 80, 100, 125, 160, 200, 250, 320, 400, 500	2000	1000	2000	1000	500	800
40	25, 50, 80, 100, 125, 160, 200, 250, 320, 400, 500	2000	1900	2000	1900	500	800
50	25, 50, 80, 100, 125, 160, 200, 250, 320, 400, 500, 600	2000	1900	2000	1900	600	1000
63	25, 50, 80, 100, 125, 160, 200, 250, 320, 400, 500, 600	2000	1900	2000	1900	600	1000
80	25, 50, 80, 100, 125, 160, 200, 250, 320, 400, 500, 600, 700, 800	2000	1900	2000	1900	800	1000
100	25, 50, 80, 100, 125, 160, 200, 250, 320, 400, 500, 600, 700, 800	2000	1900	2000	1900	800	1000
125	—	2000	2000	1000	1000	—	1000

Intermediate strokes are available

Note) Please consult with SMC for longer strokes

• Rod

—	Single rod
W ^{Note)}	Double rod

Note) Not available in Smooth cylinder

• Made to order^{Note)}
Note) Refer to "Made to order" table in next page

• Rod boot^{Note 1)}

—	Without boot
J	Nylon tarpaulin (one end)
JJ ^{Note 2)}	Nylon tarpaulin (both ends)
K	Heat resistant tarpaulin (one end)
KK ^{Note 2)}	Heat resistant tarpaulin (both ends)

Note 1) Only for Standard type
Note 2) In case of double rod

• Cushion

—	Air cushion ^{Note)}
C	Air and Bumper cushion

Note) For bore size 125 only

X option combinations available to order

Symbol	XA□	XB6 ¹⁾	XC4	XC7	XC14	XC22	XC68	XC88
XA□								
XB6 ¹⁾	●							
XC4	●	X						
XC7	● ³⁾	●	●					
XC14	● ³⁾	●	●	X				
XC22	●	—	X	●	● ²⁾			
XC68	● ³⁾	●	●	●	● ^{2,3)}	●		
XC88	●	—	—	●	● ²⁾	●	—	
XC89	●	—	—	●	● ²⁾	●	●	—

●: Combination possible to produce

X: Combination possible to produce but contact with SMC

—: Combination not produced

Note 1) Only for without magnet type

Note 2) If XC14A (trunnion next to the rod end) or XC14B (trunnion next to the head end) are required, the X combination is considered as Standard

Note 3) These X option combinations also available for Smooth cylinder

If you want to order a combination of non Simple Special options, just add the X options by alphabetical order at the end of the part number, for example: XC7C22 or XC14AC68



Made to order

Symbol	Details	How to order	C96S-C	CP96S-C	C96Y-C
—	Standard		●	●	—
—	Smooth cylinder		—	—	●
XA0~30	Change of rod end shape	Please use SMC's simple special system and configurators	●	●	●
XC14	Change of trunnion bracket position	Please use SMC's simple special system and configurators	●	—	●
XB6	Heat resistant cylinder (-10~150 °C)	C(P)96S□□-□C□(W)-XB6 ^{Note 7)}	●	●	—
XB7	Cold resistant cylinder (-40~70 °C)	C96SB□-□C□-XB7 ^{Note 7)}	●	—	—
XC4 ^{Note 1)}	With Heavy Duty Scraper (protection against particles)	C(P)96SD□□-□C□(W)-XC4	●	●	—
XC7	Tie rod, cushion valve, and tie rod nut, made of stainless steel	C(P)96SD□□-□C□(W)-XC7	●	●	●
XC10 ^{Note 2,3)}	Dual stroke cylinder / Double rod type (back to back)	C(P)96SD□□-□+□C-XC10	●	●	●
XC11 ^{Note 4,5)}	Dual Stroke Cylinder/Single Rod Type (in line)	C(P)96SD□□-□+□C-XC11	●	●	—
XC22	Fluoro rubber seals (for chemical splashes)	C(P)96SD□□-□C□(W)-XC22	●	●	—
XC35	With Coil Scraper (when frost, weld spatter or others adhere to rod)	C(P)96SD□□-□C□(W)-XC35	●	●	—
XC65 ^{Note 6)}	Made of Stainless Steel (Combination of -XC7 and -XC68)	C(P)96SD□□-□C□(W)-XC65	●	●	●
XC68 ^{Note 6)}	Piston rod, and rod end nut made of stainless steel	C(P)96SD□□-□C□(W)-XC68	●	●	●
XC88	Spatter resistant coil scraper, Lube-retainer, Grease for welding (Piston rod: Stainless steel 304)	C(P)96SD□□-□C□(W)-XC88	●	●	—
XC89	Spatter resistant coil scraper, Lube-retainer, grease for welding (Piston rod: S45C)	C(P)96SD□□-□C□(W)-XC89	●	●	—

Note 1) Up to Ø 100

Note 2) Not possible with clevis and trunnion mounting type

Note 3) XC10 is not possible for double rod cylinder

Note 4) XC11 in a double rod cylinder, please consult SMC

Note 5) Not possible with trunnion mounting type

Note 6) Maximum strokes differ from the standard in the single rod types. In CP96-C – Ø 32: **1800**, in CP96-C and C96-C – Ø 40 to Ø 100: **1700** and in CP96 and C96 – Ø 125: **1600**

Note 7) Not possible with the built in magnet type, so do not add the "D" in the part number

Specifications

Standard / Non Rotating type

Bore size [mm]	32	40	50	63	80	100
Action	Double acting					
Fluid	Air					
Proof pressure	1.5 MPa					
Max. operating pressure	1.0 MPa					
Min. operating pressure	0.05 MPa					
Ambient and fluid temperature	Without auto switch: -20 to 70 °C (No freezing) With auto switch: -10 to 60 °C (No freezing)					
Lubrication	Not required (Non-lube)					
Operating piston speed	50 to 1000 mm/s					
Cushion	Air cushion on both ends + Bumper cushion					
Non-Rotating accuracy	±0.5°			±0.3°		

Smooth type

Bore size [mm]	32	40	50	63	80	100
Action	Double acting					
Fluid	Air					
Proof pressure	1.05 MPa					
Max. operating pressure	0.7 MPa					
Min. operating pressure	0.02 MPa	0.01 MPa				
Ambient and fluid temperature	Without auto switch: -10 to 70 °C (No freezing) With auto switch: -10 to 60 °C (No freezing)					
Lubrication	Not required (Non-lube)					
Operating piston speed	5 to 500 mm/s					
Cushion	Air cushion on both ends + Bumper cushion					
Allowable leakage rate	0.5 l/min (ANR)					

Availability: Stocked items for fast delivery & Manufacturing (European and Local)

Stocked items for fast delivery

Part Number	Stroke (□)
CP96SDB32-□C	25, 40, 50, 60, 70, 80, 100, 125, 150, 160, 200, 250, 300, 320, 400, 500
CP96SDB40-□C	25, 30, 40, 50, 70, 80, 100, 125, 150, 160, 200, 250, 300, 320, 400, 500
CP96SDB50-□C	25, 30, 40, 50, 60, 70, 80, 100, 125, 150, 160, 200, 250, 300, 320, 500
CP96SDB63-□C	25, 30, 40, 50, 60, 70, 80, 100, 125, 150, 160, 200, 250, 300, 320, 500
CP96SDB80-□C	25, 30, 40, 50, 60, 70, 80, 100, 125, 150, 160, 200, 250, 300, 320, 400, 500
CP96SDB100-□C	25, 50, 80, 100, 125, 160, 200, 250, 300, 320, 500
CP96SDB125-□	25, 50, 80, 100, 125, 160, 200, 250, 320, 400, 500

Stocked items could be subject to change without prior notice

Stocked items for fast delivery

Part Number	Stroke (□)
C96SDB32-□C	25, 50, 80, 100, 125, 160, 200, 250, 320
C96SDB40-□C	25, 50, 80, 100, 125, 160, 200, 250, 320
C96SDB50-□C	25, 50, 80, 100, 125, 160, 200, 250, 320
C96SDB63-□C	25, 50, 80, 100, 125, 160, 200, 250, 320
C96SDB80-□C	25, 50, 80, 100, 125, 160, 200, 250, 320
C96SDB100-□C	25, 50, 80, 100, 125, 160, 200, 250, 320

Stocked items could be subject to change without prior notice

European Manufacturing

3 days Production:

- Intermediate strokes
- Longer than standard strokes

5 days Production:

- Non Rotating cylinder
- Double rod cylinder
- Double rod + Non Rotating cylinder
- Smooth cylinder
- ATEX compliant version
- Change of rod end shape - XA0~30
- Heat resistant cylinder (-10 ~ 150 °C) - XB6
- Cold resistant cylinder (-40 ~ 70 °C) - XB7
- Tie rod, cushion valve and tie rod nut made of stainless steel - XC7
- Piston rod and rod end nut made of stainless steel - XC68

Local Manufacturing

(from 1 to 6 days Production):

Customised C(P)96-C

For emergency orders or other delivery dates, please consult with SMC

For orders up to 10 pcs, delivery dates are a guideline



ATEX compliant version (ATEX directive category 2)

Classification	With magnet type D
II 2 GD c	T 85 °C (T5) Ta -10 °C to 40 °C
	T 105 °C (T4) Ta 40 °C to 60 °C



How to Order

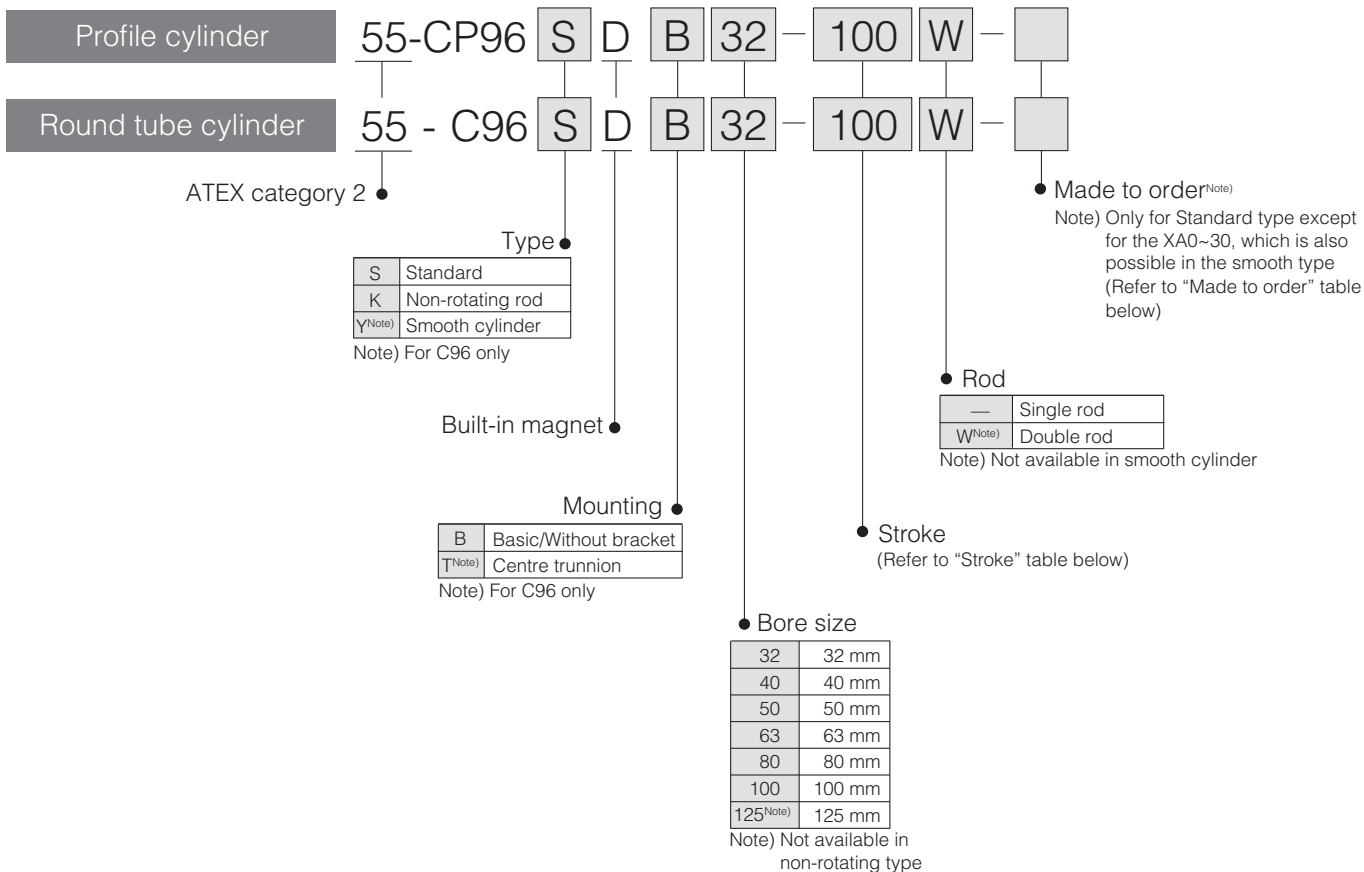

Stroke

Bore size [mm]	Standard stroke [mm]	Single rod		Double rod		C(P)96K ^{Note)} Max. stroke	C96Y ^{Note)} Max. stroke
		CP96 ^{Note)} Max. stroke	C96 ^{Note)} Max. stroke	CP96 ^{Note)} Max. stroke	C96 ^{Note)} Max. stroke		
32	25, 50, 80, 100, 125, 160, 200, 250, 320, 400, 500	2000	1000	1000	1000	500	800
40	25, 50, 80, 100, 125, 160, 200, 250, 320, 400, 500	2000	1900	1000	1000	500	800
50	25, 50, 80, 100, 125, 160, 200, 250, 320, 400, 500, 600	2000	1900	1000	1000	600	1000
63	25, 50, 80, 100, 125, 160, 200, 250, 320, 400, 500, 600	2000	1900	1000	1000	600	1000
80	25, 50, 80, 100, 125, 160, 200, 250, 320, 400, 500, 600, 700, 800	2000	1900	1000	1000	800	1000
100	25, 50, 80, 100, 125, 160, 200, 250, 320, 400, 500, 600, 700, 800	2000	1900	1000	1000	800	1000
125	—	2000	2000	1000	1000	—	1000

Intermediate strokes are available

Note) Please consult with SMC for longer strokes

Made to order

Symbol	Details	How to order	C96	CP96
—	Standard		●	●
XA0~30	Change of rod end shape	Please use SMC's simple special system and configurators	●	●
XC14	Change of trunnion bracket position	Please use SMC's simple special system and configurators	●	—
XC4 ^{Note 1)}	With Heavy Duty Scraper (protection against particles)	C(P)96SD□□-□□(W)-XC4	●	●
XC7	Tie rod, cushion valve, and tie rod nut, made of stainless steel	C(P)96SD□□-□□(W)-XC7	●	●
XC22	Fluoro rubber seals (for chemical splashes)	C(P)96SD□□-□□(W)-XC22	●	●
XC68 ^{Note 2)}	Piston rod, and rod end nut made of stainless steel	C(P)96SD□□-□□(W)-XC68	●	●

Note 1) Up to Ø 100

Note 2) The maximum strokes differ from the standard in the single rod types. In CP96 - Ø 32: **1800**, in CP96 and C96 - Ø 40 to Ø 100: **1700** and in CP96 and C96 - Ø 125: **1600**



CP96-C and C96-C – Accesories/Related Products

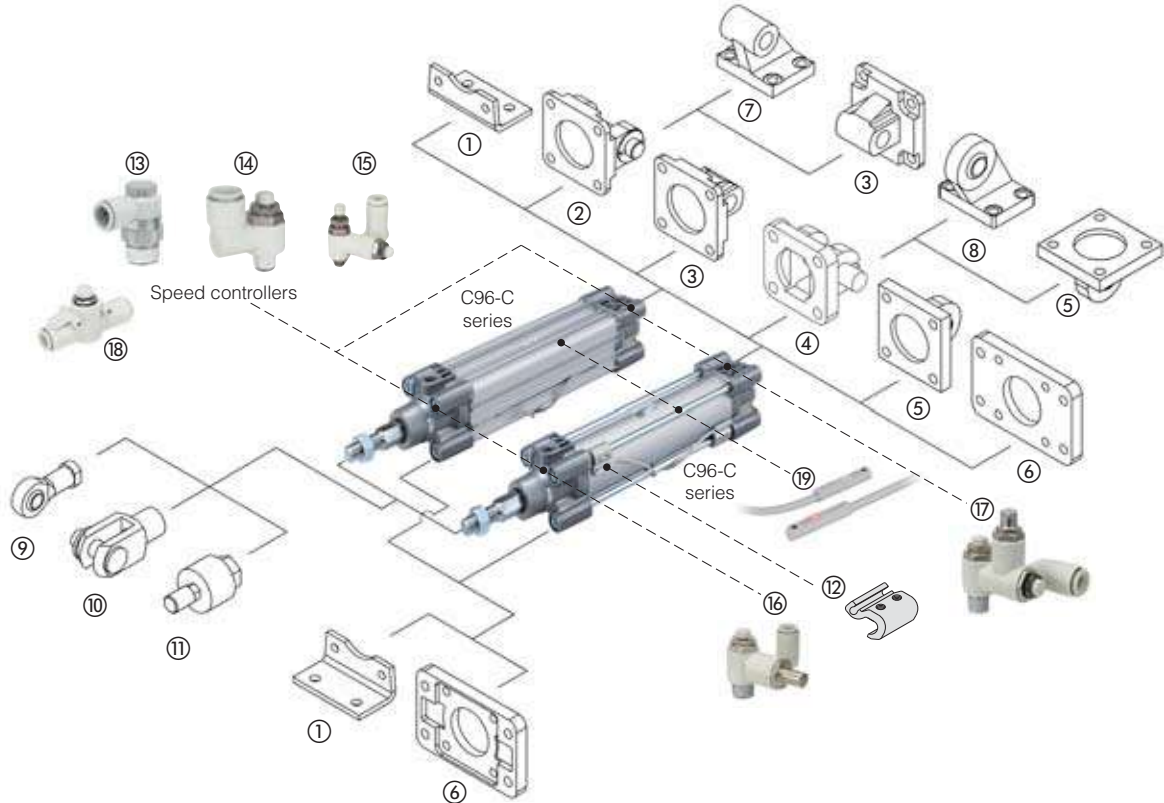

Bore size [mm]	①	②	③	④	⑤	⑥	⑦	⑧	⑨	⑩	⑪	⑫
	Foot (Supplied with two pieces and 4 screws)	Female head end clevis (Corresponds to E accessory) (Supplied with bolt, safety device and 4 screws)	Male head end clevis (Supplied with 4 screws)	Female head end clevis (for ES accessory) (Supplied with bolt, safety device and 4 screws)	Male head end clevis with ball joint (Supplied with 4 screws)	Rod/Head end flange (Supplied with 4 screws)	Angled head end clevis	Angled head end clevis with ball joint	Piston rod ball joint (ISO 8139)	Rod clevis (ISO 8140) (Supplied with bolt and safety device)	Floating joint	Auto switch mounting bracket (C96 only)
32	L5032	D5032	C5032	DS5032	CS5032	F5032	E5032	ES5032	KJ10D	GKM10-20	JA30-10-125	BMB5-032
40	L5040	D5040	C5040	DS5040	CS5040	F5040	E5040	ES5040	KJ12D	GKM12-24	JA40-12-125	
50	L5050	D5050	C5050	DS5050	CS5050	F5050	E5050	ES5050	KJ16D	GKM16-32	JA50-16-150	BA7-040
63	L5063	D5063	C5063	DS5063	CS5063	F5063	E5063	ES5063	KJ16D	GKM16-32	JA50-16-150	
80	L5080	D5080	C5080	DS5080	CS5080	F5080	E5080	ES5080	KJ20D	GKM20-40	JAH50-20-150	BA7-063
100	L5100	D5100	C5100	DS5100	CS5100	F5100	E5100	ES5100	KJ20D	GKM20-40	JAH50-20-150	
125 ^{Note 1)}	L5125	D5125	C5125	DS5125	CS5125	F5125	E5125	ES5125	KJ27D	GKM30-54	JA125-27-200	BA7-080

Bore size [mm]	Ø tube	⑬	⑭	⑮	⑯	⑰	Bore size [mm]	⑱				
		Speed controller elbow type	Speed controller universal type	Dual speed controller	Air saving valve Pressure valve	Air saving valve Flow valve		Speed controller in-line type	Auto switch			
		Part number	Part number	Part number	Part number	Part number	Ø tube	Part No. ^{Note 2)}	Solid state type - 2 colour indication			
32	3,2	AS2201F-01-23A	AS2301F-01-23	—	—	—	32	4	AS2002F-04	Part No.	Wiring	Cable
	4	AS2201F-01-04SA	AS2301F-01-04S	—	—	D-M9BWL				2 wire	3 m	
	6	AS2201F-01-06SA	AS2301F-01-06S	ASD330F-01-06S	—	—				D-M9PWL	3 wire PNP	3 m
	8	AS2201F-01-08SA	AS2301F-01-08S	ASD330F-01-08S	—	—				D-M9PWSAPC	M8-3pin PNP	0.5 m
40, 50	4	AS2201F-02-04SA	AS2301F-02-04S	—	—	—	40, 50	6	AS2052F-06	For ATEX ^{Note 3)}		
	6	AS2201F-02-06SA	AS2301F-02-06S	ASD430F-02-06S	ASR430F-02-06S	ASQ430F-02-06S				D-M9BWL-588	2 wire	3 m
	8	AS2201F-02-08SA	AS2301F-02-08S	ASD430F-02-08S	ASR430F-02-08S	ASQ430F-02-08S				D-M9PWL-588	3 wire PNP	3 m
	10	AS2201F-02-10SA	AS2301F-02-10S	ASD430F-02-10S	ASR430F-02-10S	ASQ430F-02-10S				D-M9PWSAPC-588	M8-3pin PNP	0.5 m
63, 80	12	—	AS2301F-02-12S	ASD430F-02-12S	ASR430F-02-12S	ASQ430F-02-12S	63	10	AS3002F-10	Reed type		
	6	AS3201F-03-06SA	AS3301F-03-06S	ASD530F-03-06S	ASR530F-03-06S	ASQ530F-03-06S				Part No.	Wiring	Cable
	8	AS3201F-03-08SA	AS3301F-03-08S	ASD530F-03-08S	ASR530F-03-08S	ASQ530F-03-08S				D-A93L	2 wire	3 m
	10	AS3201F-03-10SA	AS3301F-03-10S	ASD530F-03-10S	ASR530F-03-10S	ASQ530F-03-10S				D-A93SAPC	M8-3pin	0.5 m
100, 125 ^{Note 1)}	12	AS3201F-03-12SA	AS3301F-03-12S	ASD530F-03-12S	ASR530F-03-12S	ASQ530F-03-12S	80, 100, 125	12	AS4002F-12	For ATEX ^{Note 3)}		
	10	AS4201F-04-10SA	AS4301F-04-10S	ASD630F-04-10S	ASR630F-04-10S	ASQ630F-04-10S				D-A93L-588	2 wire	3 m
	12	AS4201F-04-12SA	AS4301F-04-12S	ASD630F-04-12S	ASR630F-04-12S	ASQ630F-04-12S						
	12	AS4201F-04-12SA	AS4301F-04-12S	ASD630F-04-12S	ASR630F-04-12S	ASQ630F-04-12S						

Note 1) Only available for series C96 and CP96

Note 2) Ø 125: Can also use a large flow in-line type speed controller: AS420-04

Note 3) When mounting an auto switch on a 55-series (Category 2) model, the ATEX class of the cylinder with auto switch changes to Category 3, which is the same class as the auto switch. Auto switch only conforms to Category 3. (II 3GD EEx nA II T5x -10 °C ≤ Ta ≤ +60 °C IP67)

Series C95 ISO 6431



ISO/VDMA Standard [ISO 6431]. Tie rod cylinder

Standard type

Double Acting, Single Rod

Series C95

Ø 160, Ø 200, Ø 250

- Strokes up to 2400 mm
- Operating piston speed up to 500 mm/s
- ATEX compliant version for explosive atmospheres
- Auto switch tie rod mounting

Double acting,
Single rod

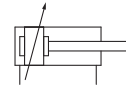

How to Order

C95 S D B 200 - 160

Standard

Built-in magnet

Mounting

B	Basic/Without bracket
T	Centre trunnion

Bore size

160	160 mm
200	200 mm
250	250 mm

Stroke

Bore size [mm]	Max. stroke ^{Note)}
160	1600
200	2000
250	2400

Intermediate strokes are available
Note) Please consult with SMC for longer strokes

Specifications

Bore size [mm]		160	200	250
Action		Double acting		
Fluid		Air		
Proof pressure		1.5 MPa		
Max. operating pressure		1.0 MPa		
Min. operating pressure		0.05 MPa		
Ambient and fluid temperature	Without auto switch	-10 to 70 °C ^{Note)} (No freezing)		
	With auto switch	-10 to 60 °C (No freezing)		
Lubrication		Not required (Non-lube)		
Operating piston speed		50 to 500 mm/s		
Cushion		Both ends (Air cushion)		

Note) ATEX version: -10 to 60 °C (No freezing)

Availability: Stocked items for fast delivery & Manufacturing (Local)

Stocked items for fast delivery

Part Number	Stroke (□)
CP95SDB160-□	100, 125, 200, 250, 320, 400, 500
CP95SDB200-□	100, 200

Stocked items could be subject to change without prior notice

For emergency orders or other delivery dates, please consult with SMC
For orders up to 10 pcs, delivery dates are a guideline

Local Manufacturing

(from 1 to 6 days Production):
Customised C95

ATEX compliant version (ATEX directive category 2)

Classification	
II 2 GD c	95 °C (T5) Ta -10 °C to 40 °C 115 °C (T4) Ta 40 °C to 60 °C



How to Order

55-C95SD B 200 - 160

ATEX category 2

Standard

Built-in magnet

Mounting

B	Basic/Without bracket
T	Centre trunnion

Bore size

160	160 mm
200	200 mm
250	250 mm

Stroke

Each stroke will be made to order

Bore size [mm]	Max. stroke [mm] ^{Note)}
160	1600
200	2000
250	2400

Note) Please consult with SMC for longer strokes

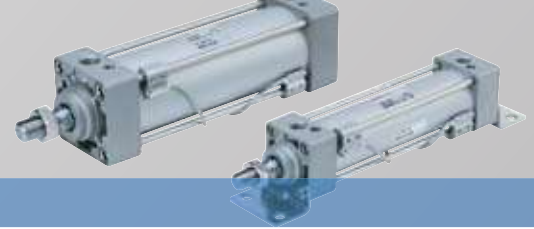

C95 – Accesories/Related Products

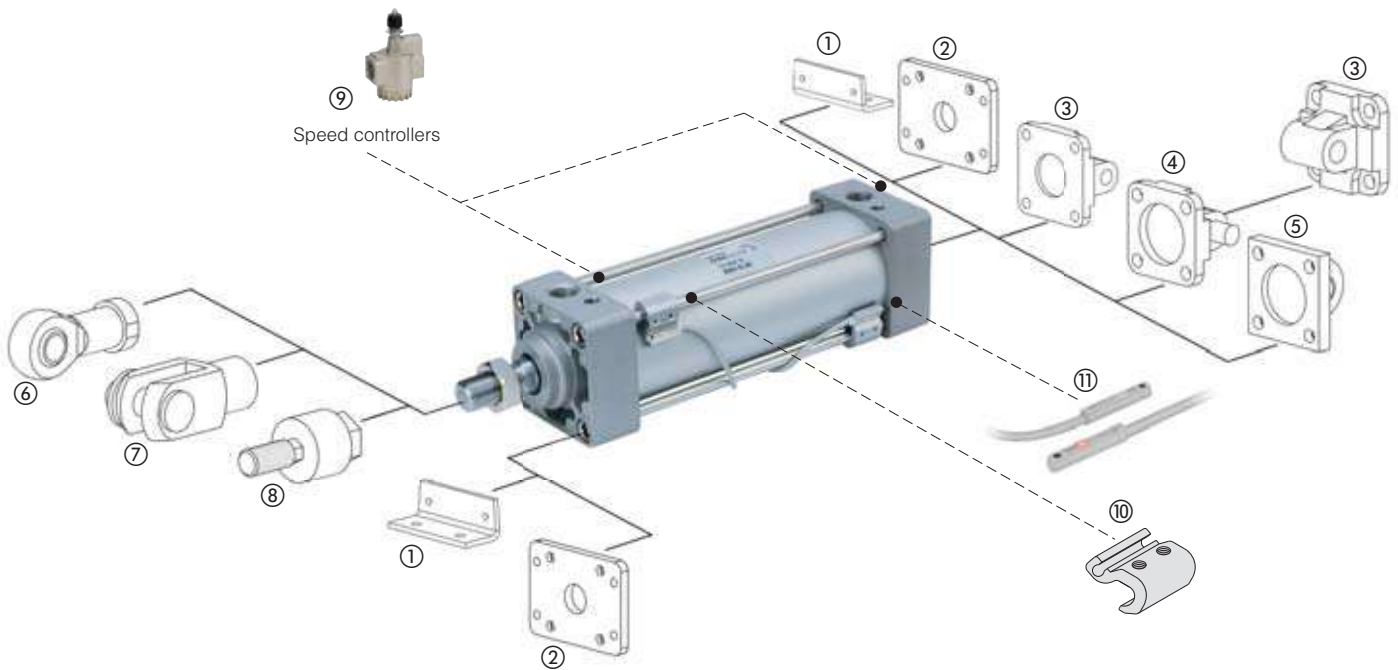

Bore size [mm]	①	②	③	④	⑤	⑥	⑦	⑧	⑨	⑩
	Foot (Supplied with two pieces and 4 screws)	Flange (Supplied with 4 screws)	Single rear clevis (Supplied with 4 screws)	Double rear clevis (Supplied with bolt, safety device and 4 screws)	Male head end clevis with ball joint (Supplied with 4 screws)	Piston rod ball joint (ISO 8139)	Rod clevis (ISO 8140) (Supplied with bolt and safety device)	Floating joint	Speed controller Large flow in-line type	Auto switch mounting bracket
160	L5160	F5160	C5160	D5160	CS160	KJ36D	GKM35-54	JA160-36-200	AS500-06	BS5-160
200	L5200	F5200	C5200	D5200	CS200	KJ36D	GKM35-54	JA160-36-200	AS500-06	BS5-160
250	L5250	F5250	C5250	D5250	CS250	KJ42D	GKM40-84	—	AS600-10	BT-20

Bore size [mm]	⑪				
	Solid state 2-colour indication auto-switch			Reed auto switch	
	2 wire	3 wire PNP	M8-3pin PNP	2 wire	M8-3pin
	3 m cable	3 m cable	0.5 m cable	3 m cable	0.5 m cable
160, 200	D-M9BWL	D-M9PWL	D-M9PWSAPC	D-A93L	D-A93SAPC
250	D-J59WL	D-F5PWL	D-F5PWSAPC	D-A54L	—

For ATEX ^(Note)

160, 200	D-M9BWL-588	D-M9PWL-588	D-M9PWSAPC-588	D-A93L-588	D-A93SAPC-588
250	D-J59WL-588	D-F5PWL-588	D-F5PWSAPC-588	D-A54L-588	—

Note) When mounting an auto switch on a 55-series (Category 2) model, the ATEX class of the cylinder with auto switch changes to Category 3, which is the same class as the auto switch. Auto switch only conforms to Category 3. (II 3GD EEx nA II T5x -10 °C ≤ Ta ≤ +60 °C IP67)

Series C85 ISO 6432



ISO Standard [ISO 6432]. Round Crimped Body Cylinder Standard / Non-rotating Type Double/Single Acting, Single/Double Rod Series C85 Ø 8, Ø 10, Ø 12, Ø 16, Ø 20, Ø 25

- Special rod seal gives high resistant to dusty environments
- Strokes up to 1000 mm
- High speed actuation, up to 1500 mm/s
- ATEX compliant version for explosive atmospheres
- Auto switch band mounting

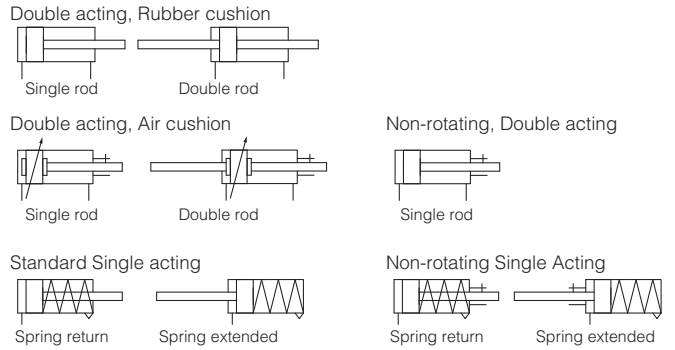

How to Order Standard and Non-Rotating type

Single acting C D 85 [] N 16 - 40 S - B []

Double acting Single rod C D 85 [] N 16 - 40 C J - B []

Double acting Double rod C D 85 W [] E 16 - 40 [] JJ - B []

Built-in magnet

—	None
D	Built-in magnet

Type

—	Standard
K	Non-rotating rod (Rubber cushion only)

Mounting

N ^{Note 1)}	Basic (integrated clevis)
E ^{Note 2)}	Double end boss-cut style
F	Boss-cut basic style
Y ^{Note 3)}	Head cover axial port

Note 1) N type is only applicable for air cushion type
Note 2) E type is only applicable for double rod
Note 3) Except single acting/spring extended type

Action

S	Single acting, Spring return
T	Single acting, Spring extended

Other options

—	None
XA0~30 ^{Note)}	Change of Rod end shape
XC6A	Stainless steel piston rod and piston rod nut
XC6B	Stainless steel piston rod, piston rod nut and mounting nut

Note) Ø 8 to Ø 16: only possible XA0/1/10/11
Ø 20 to Ø 25 (except Non-rotating type): XA0 to XA30 possible
Ø 20 to Ø 25 (Non-rotating type): XA0/1/6/10/11/13/14/17/19/21

Other options

—	None
XA0~30 ^{Note 1)}	Change of Rod end shape
XB6 ^{Note 2)3)4)}	High Temperature
XB7 ^{Note 2)3)5)6)}	Low Temperature
XB9 ^{Note 3)5)6)7)}	Low Speed
XC4 ^{Note 5)6)8)}	Heavy-duty Scraper
XC6A ^{Note 9)}	Stainless steel piston rod and piston rod nut
XC6B ^{Note 9)}	Stainless steel piston rod, piston rod nut and mounting nut

Note 1) Ø 8 to Ø 16: only possible XA0/1/10/11
Ø 20 to Ø 25 (except Non-rotating type): XA0 to XA30 possible
Ø 20 to Ø 25 (Non-rotating type): XA0/1/6/10/11/13/14/17/19/21
Note 2) Without magnets
Note 3) Contact SMC for Non-rotating type
Note 4) In Double rod and/or air cushion type, only available for Ø 20 and Ø 25
Note 5) Only rubber cushion
Note 6) Only Ø 20, Ø 25
Note 7) Only single rod
Note 8) Not applicable for Non-rotating type
Note 9) In air cushion type, only Ø 10, 12 and 16 possible

Auto switch mounting

—	Without auto switch
B	Band mounting

Rod boot (only Ø 20, Ø 25)

—	Without rod boot
J	Nylon tarpaulin (one side)
K	Heat resistant tarpaulin (one side)
JJ ^{Note)}	Nylon tarpaulin (both sides)
KK ^{Note)}	Heat resistant tarpaulin (both sides)

Note) In case of double acting/double rod

Cushion

—	Rubber cushion (Standard)
C	Air cushion (Only "N" execution, bores 10 to 25 mm)

Bore size **Stroke** **Stroke**

Bore size [mm]	Double acting			Single acting	
	Standard stroke [mm] ^{Note 2)}	Max. stroke [mm] ^{Note 3)}		Standard stroke [mm] ^{Note 2)}	Max. stroke [mm]
Standard		Non-rotating	Double rod		
8 ^{Note 1)}	10, 25, 40, 50, 80, 100	200	100	100	10, 25, 40, 50
10		400	200	200	
12	10, 25, 40, 50, 80, 100, 125, 160, 200	400	200	200	10, 25, 40, 50, 80, 100, 125, 150
16		1000	1000	500	
20	10, 25, 40, 50, 80, 100, 125, 160, 200, 250, 300	1000	1000	500	150
25		1000	1000	500	

Note 1) Not available with air cushion
Note 2) Other strokes available on request
Note 3) When exceeding the standard stroke range, it will be available as made to order (X2018)



How to Order Direct Mount Type

Double acting
Single rod

C D 85R A F 16 - 40 - B

Built-in magnet ●

—	None
D	Built-in magnet

Type ●

A	Bottom side mounting
B ^{Note)}	Front side mounting

Note) Only Ø 20, Ø 25

Mounting ●

F	Boss-cut basic style
Y	Head cover axial port

● Other options

—	None
XA0~30 ^{Note 1)}	Change of Rod end shape
XB6 ^{Note 2)}	High Temperature
XB7 ^{Note 2)3)}	Low Temperature
XB9 ^{Note 3)}	Low Speed
XC6A	Stainless steel piston rod and piston rod nut

Note 1) Ø 8 to Ø 16: only possible XA0/1/10/11
Ø 20 to Ø 25: XA0 to XA30 possible

Note 2) Without magnets

Note 3) Only Ø 20, Ø 25

● Auto switch mounting

—	Without auto switch
B	Band mounting

● Bore size

● Stroke

Bore size [mm]	Standard stroke [mm] ^{Note 1)}	Max. stroke [mm] ^{Note 2)}
8	10, 25, 40, 50, 80, 100	200
10		
12	10, 25, 40, 50, 80, 100 125, 160	400
16		
20	10, 25, 40, 50, 80, 100 125, 160	1000
25		

Note 1) Other strokes on available request

Note 2) For exceeding the standard stroke range, it will be available as a special order (X2018)

Specifications

Standard / Non-rotating type

Bore size [mm]	8	10	12	16	20	25	
Action	Double/Single Acting, Single/Double Rod						
Fluid	Air						
Proof pressure	1.5 MPa						
Max. operating pressure	1.0 MPa						
Double Acting Min. operating pressure	Spring return	0.1 MPa	0.08 MPa	0.05 MPa	0.05 MPa		
	Spring extended				0.08 MPa		
Single Acting Min. operating pressure	Spring return	0.22 MPa	0.18 MPa	0.13 MPa	0.18 MPa		
	Spring extended				0.23 MPa		
Ambient and fluid temperature	-20 to 80 °C (Built-in magnet: -10 to 60 °C) No freezing						
Cushion	Rubber cushion, Air cushion (Only "N" execution, bores 10 to 25 mm), (Non-rotating and Single Acting: Rubber cushion only)						
Lubrication	Not required. Use turbine oil Class 1 ISO VG32, if lubricated						
Piston speed	50 to 1500 mm/s						
Allowable kinetic energy	Rubber cushion	0.02 J	0.03 J	0.04 J	0.09 J	0.27 J	0.4 J
	Air cushion	—	0.17 J	0.19 J	0.4 J	0.64 J	0.93 J
Non-rotating accuracy	±1° 30'	±1° 30'	±1°	±1°	±0° 42'	±0° 42'	

Direct mount type

Bore size [mm]	8	10	12	16	20	25
Action	Double Acting, Single Rod					
Fluid	Air					
Proof pressure	1.5 MPa					
Max. operating pressure	1.0 MPa					
Min operating pressure	0.1 MPa	0.08 MPa	0.05 MPa			
Ambient and fluid temperature	-20 to 80 °C (Built-in magnet: -10 to 60 °C)					
Cushion	Rubber bumper (Standard)					
Lubrication	Not required. If necessary, turbine oil no. 1 ISO VG32 is recommended					
Piston speed	50 to 1500 mm/s					
Allowable kinetic energy	0.02 J	0.03 J	0.04 J	0.09 J	0.27 J	0.4 J



Availability: Stocked items for fast delivery & Manufacturing (European and Local)

Stocked items for fast delivery

Part Number (Without auto switch)	Part Number (With auto switch)	Stroke (□)
C85N8-□	CD85N8-□-B	10, 25, 40, 50, 80, 100
C85N8-□*	CD85N8-□*-B	10, 25, 50
C85N10-□	CD85N10-□-B	10, 25, 40, 50, 80, 100
C85N10-□C	CD85N10-□C-B	10, 25, 40, 50, 80
C85N10-□*	CD85N10-□*-B	10, 25, 50
C85N12-□	CD85N12-□-B	10, 25, 40, 50, 80, 100, 125, 160, 200
C85N12-□C	CD85N12-□C-B	10, 25, 40, 50, 80, 100, 125, 160, 200
C85N12-□*	CD85N12-□*-B	10, 25, 50
C85N16-□	CD85N16-□-B	10, 25, 40, 50, 80, 100, 125, 160, 200
C85N16-□C	CD85N16-□C-B	10, 25, 40, 50, 80, 100, 125, 160, 200
C85N16-□*	CD85N16-□*-B	10, 25, 50
C85N20-□	CD85N20-□-B	10, 25, 40, 50, 80, 100, 125, 160, 200, 250, 300
C85N20-□C	CD85N20-□C-B	10, 25, 40, 50, 80, 100, 125, 160, 200, 250, 300
C85N20-□*	CD85N20-□*-B	10, 25, 50, 100
C85N25-□	CD85N25-□-B	10, 25, 40, 50, 80, 100, 125, 160, 200, 250, 300
C85N25-□C	CD85N25-□C-B	10, 25, 40, 50, 80, 100, 125, 160, 200, 250, 300
C85N25-□*	CD85N25-□*-B	10, 25, 50
	CD85WE16-□-B	10, 25, 40, 50, 80, 100, 125, 160, 200
	CD85WE20-□-B	10, 25, 40, 50, 80, 100, 125, 160, 200, 250, 300
	CD85WE25-□-B	10, 25, 40, 50, 80, 100, 125, 160, 200, 250, 300

Stocked items could be subject to change without prior notice

*: Action S: Single action, spring return
T: Single action, spring extend

European Manufacturing

3 days Production:
• Intermediate strokes

5 days Production:

- Longer than standard strokes - X2018
- Non Rotating cylinder
- Double rod cylinder
- ATEX compliant version
- Change of rod end shape - XA0~30
- Heat resistant cylinder (-10 ~ 150 °C) - XB6
- Cold resistant cylinder (-40 ~ 70 °C) - XB7
- Low speed cylinder - XB9
- Stainless steel piston rod and piston rod nut - XC6A
- Stainless steel piston rod, piston rod nut and mounting nut - XC6B

Local Manufacturing

(from 1 to 6 days Production):
Customised C85

For emergency orders or other delivery dates, please consult with SMC

For orders up to 10 pcs, delivery dates are a guideline

ATEX compliant version (ATEX directive category 2)

Classification	
II 2 GD c	90 °C (T5) Ta -10 °C to 40 °C 110 °C (T4) Ta 40 °C to 60 °C



How to Order

Double acting Single rod → 55-C D 85 K N 20 - 40 C - B - □
Double acting Double rod → 55-C D 85 W E 20 - 40 □ - B - □

ATEX category 2
 Built in magnet: □ None, D Built-in magnet
 Type: □ Standard, K Non rotating rod (Rubber cushion only)

Mounting

Symbol	Mounting
N ^{Note 1)}	Basic integrated clevis
E ^{Note 2)}	Double end type
F	Front nose type
Y	Front nose in line port

 Note 1) N type is only applicable for air cushion type
 Note 2) E type is only applicable for double rod

Other options

□	Standard
XC6A	Stainless steel piston rod and piston rod nut
XC6B	Stainless steel piston rod, piston rod nut and mounting nut

Auto switch mounting

□	Without auto switch
B	Band mounting

Cushion

□	Rubber bumper (Standard)
C	Air cushion (only "N" execution, bores 10 to 25 mm)

Bore size **Stroke**

Bore size [mm]	Standard stroke [mm] ^{Note 2)}	Max. stroke [mm] ^{Note 3)}		
		Standard	Non-rotating	Double rod
8 ^{Note 1)}	10, 25, 40, 50, 80, 100	200	100	100
10	10, 25, 40, 50, 80, 100, 125, 160, 200	400	200	200
12				
16				
20	10, 25, 40, 50, 80, 100, 125, 160, 200, 250, 300	1000	1000	500
25				

Note 1) Not available with air cushion

Note 2) Other strokes available on request

Note 3) For exceeding the standard stroke range, it will be available as made to order (X2018)

Specifications

Bore size [mm]	8	10	12	16	20	25
Action	Double acting					
Fluid	Air					
Proof pressure	1.5 MPa					
Max. operating pressure	1.0 MPa					
Min. operating pressure	0.1 MPa	0.08 MPa		0.05 MPa		
Ambient and fluid temperature	-10 to 60 °C (no freezing)					
Cushion	Rubber bumper, Air cushion (Except for Ø 8)					
Lubrication	Not required (Non lube)					
Piston speed	50 to 750 mm/s Rubber bumper, 50 to 1000 mm/s Air cushion					
Non-rotating accuracy	±1° 30'	±1° 30'	±1°	±1°	±0° 42'	±0° 42'

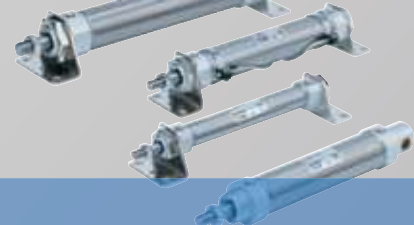

C85 – Accesories/Related Products

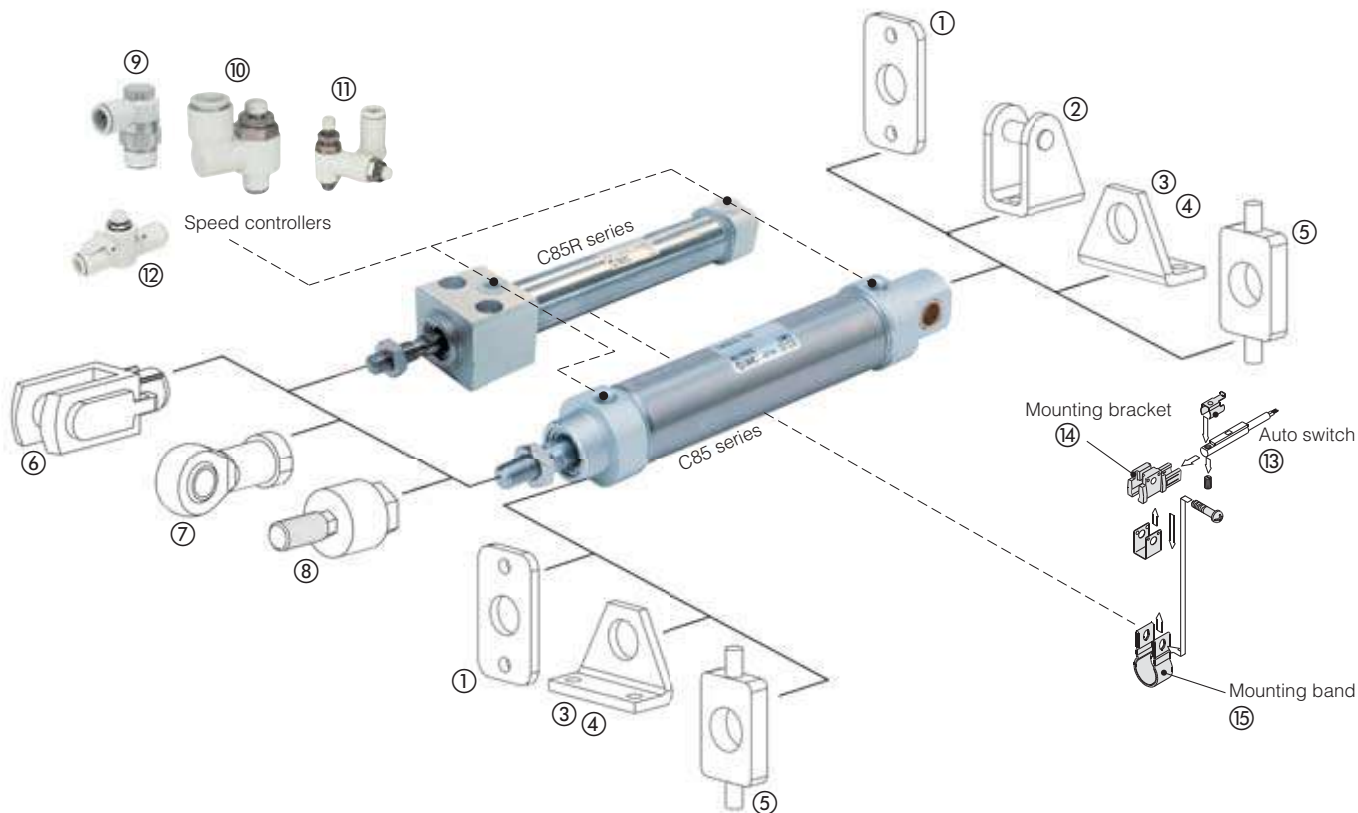

Bore size [mm]	①	②	③	④	⑤	⑥	⑦	⑧
	Front/Rear Flange	Clevis	Foot (1pc)	Foot (2 pcs) ^{Note)}	Front/Rear Trunnion	Rod clevis (ISO8140) (Supplied with bolt and safety device)	Piston rod ball joint (ISO8139)	Floating joint
8	C85F10	C85C10	C85L10A	C85L10B	C85T10	GKM4-8	KJ4D	JA10-4-070
10								
12	C85F16	C85C16	C85L16A	C85L16B	C85T16	GKM6-10	KJ6D	JA15-6-100
16								
20	C85F25	C85C25	C85L25A	C85L25B	C85T25	GKM8-16	KJ8D	JA20-8-125
25						GKM10-20	KJ10D	JA30-10-125

Note) 2 pcs with mounting nut 1 pc

Bore size [mm]	ø tube	⑨	⑩	⑪
		Speed controller elbow type Part number	Speed controller universal type Part number	Dual speed controller Part number
8, 10 12, 16	3.2	AS1201F-M5-23A	AS1301F-M5-23	—
	4	AS1201F-M5-04A	AS1301F-M5-04	ASD230F-M5-04
	6	AS1201F-M5-06A	AS1301F-M5-06	ASD230F-M5-06
20, 25	3.2	AS2201F-01-23A	AS2301F-01-23	—
	4	AS2201F-01-04SA	AS2301F-01-04S	—
	6	AS2201F-01-06SA	AS2301F-01-06S	ASD330F-01-06S
	8	AS2201F-01-08SA	AS2301F-01-08S	ASD330F-01-08S
	10	AS2201F-01-10SA	—	—

Bore size [mm]	ø tube	⑫
		Speed controller in-line type Part number
8, 10 12, 16	3.2	AS1002F-23
	4	AS1002F-04
	6	AS1002F-06
20	3.2	AS1002F-23
	4	AS2002F-04
	6	AS2052F-06
25	8	AS2052F-08
	4	AS2002F-04
	6	AS2052F-06
	8	AS2052F-08

⑬		
Auto switch		
Solid state type - 2 colour indication		
Part No.	Wiring	Cable
D-M9BWL	2 wire	3 m
D-M9PWL	3 wire PNP	3 m
D-M9PWSAPC	M8-3pin PNP	0.5 m
For ATEX ^{Note 2)}		
D-M9BWL-588	2 wire	3 m
D-M9PWL-588	3 wire PNP	3 m
D-M9PWSAPC-588	M8-3pin PNP	0.5 m

⑭		
Mounting bracket		
BJ3-1		
⑮		
Mounting Band		
BJ2-008		
BJ2-010		
BJ2-012		
BJ2-016		
BM2-020		
BM2-025		

Note 1) D-A93 type cannot be mounted on bore sizes Ø 8, Ø 10 and Ø 12
 Note 2) When mounting an auto switch on a 55-series (Category 2) model, the ATEX class of the cylinder with auto switch changes to Category 3, which is the same class as the auto switch. Auto switch only conforms to Category 3. (II 3GD EEx nA II T5x -10 °C ≤ Ta ≤ +60 °C IP67)



ISO Standard [ISO 21287]. Compact Cylinder Standard type

Double Acting, Single Rod

Series C55

Ø 20, Ø 25, Ø 32, Ø 40, Ø 50, Ø 63, Ø 80, Ø 100

- Strokes up to 150 mm
- Operating piston speed up to 500 mm/s
- ATEX compliant version for explosive atmospheres
- Possible to mount directly round D-M9□ auto switches on the 4 surfaces
- Tapped body with through holes for easy mounting
- Female and male rod threads available

Double acting, Single rod

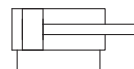

How to Order

C D 55 B 20 - 10 - - -

Built-in magnet

—	None
D	Built-in magnet

Mounting style

B	Through-hole/Both ends tapped common (Standard)
---	---

Bore size

20	20 mm
25	25 mm
32	32 mm
40	40 mm
50	50 mm
63	63 mm
80	80 mm
100	100 mm

Other options

—	None
XA1~30 ^{Note 1)}	Change of Rod end shape
XC6	Stainless steel piston rod and piston rod nut
X1439 ^{Note 2)}	Auto Switch – T-slot mounting

Note 1) Ø 20 to Ø 25 only possible XA1/2/6/7/11/17/18
Ø 32 to Ø 100: XA1 to XA23 and XA26 to 30 possible
Note 2) Only available from Ø 20 to Ø 63

Rod end thread

—	Rod end female thread
M	Rod end male thread

Stroke

Bore size [mm]	Standard stroke [mm]
20 to 63	5, 10, 15, 20, 25, 30, 35, 40, 45, 50, 60, 80, 100, 125, 150
80, 100	10, 15, 20, 25, 30, 35, 40, 45, 50, 60, 80, 100, 125

Note) Intermediate strokes by using an exclusive body are available. Order example: C55B32-47

Specifications

Type	Pneumatic (Non-lube)	
Action	Double acting, Single rod	
Fluid	Air	
Proof pressure	1.5 MPa	
Maximum operating pressure	1.0 MPa	
Minimum operating pressure	0.05 MPa (Ø 20 to Ø 63) 0.03 MPa (Ø 80, Ø 100)	
Ambient and fluid temperature	Without auto switch	-10 to 70 °C ^{Note)} (No freezing)
	With auto switch	-10 to 60 °C (No freezing)
Cushion	Rubber bumper on both end	
Piston speed	Ø 20 to Ø 63	50 to 500 mm/s
	Ø 80, Ø 100	50 to 300 mm/s

Note) ATEX version: -10 to 60 °C (No freezing)



Availability: Stocked items for fast delivery & Manufacturing (European and Local)

Stocked items for fast delivery

Part Number	Stroke (□)
C*55B20-□	5, 10, 15, 20, 25, 30, 35, 40, 45, 50, 60, 80, 100, 125, 150
C*55B20-□M	5, 10, 15, 20, 25, 30, 35, 40, 45, 50, 60, 80, 100, 125, 150
C*55B25-□	5, 10, 15, 20, 25, 30, 35, 40, 45, 50, 60, 80, 100, 125, 150
C*55B25-□M	5, 10, 15, 20, 25, 30, 35, 40, 45, 50, 60, 80, 100, 125, 150
C*55B32-□	5, 10, 15, 20, 25, 30, 35, 40, 45, 50, 60, 80, 100, 125, 150
C*55B32-□M	5, 10, 15, 20, 25, 30, 35, 40, 45, 50, 60, 80, 100, 125, 150
C*55B40-□	5, 10, 15, 20, 25, 30, 35, 40, 45, 50, 60, 80, 100, 125, 150
C*55B40-□M	5, 10, 15, 20, 25, 30, 35, 40, 45, 50, 60, 80, 100, 125, 150
C*55B50-□	5, 10, 15, 20, 25, 30, 35, 40, 45, 50, 60, 80, 100, 125, 150
C*55B50-□M	5, 10, 15, 20, 25, 30, 35, 40, 45, 50, 60, 80, 100, 125, 150
C*55B63-□	5, 10, 15, 20, 25, 30, 35, 40, 45, 50, 60, 80, 100, 125, 150
C*55B63-□M	5, 10, 15, 20, 25, 30, 35, 40, 45, 50, 60, 80, 100, 125, 150
C*55B80-□	10, 15, 20, 25, 30, 35, 40, 45, 50, 60, 80, 100, 125
C*55B80-□M	10, 15, 20, 25, 30, 35, 40, 45, 50, 60, 80, 100, 125
C*55B100-□	10, 15, 20, 25, 30, 35, 40, 45, 50, 60, 80, 100, 125
C*55B100-□M	10, 15, 20, 25, 30, 35, 40, 45, 50, 60, 80, 100, 125

Stocked items could be subject to change without prior notice

* Auto switch -: without
D: with

European Manufacturing

5 days Production:

- ATEX compliant version
- Auto switch T-slot mounting -X1439
- Change of rod end shape -XA1~30
- Stainless steel piston rod and piston rod nut -XC6

Local Manufacturing

(from 1 to 6 days Production):

Customised C55

For emergency orders or other delivery dates, please consult with SMC

For orders up to 10 pcs, delivery dates are a guideline

ATEX compliant version (ATEX directive category 2)

Classification	
II 2 GD c	85 °C (T5) Ta -10 °C to 40 °C 105 °C (T4) Ta 40 °C to 60 °C



How to Order

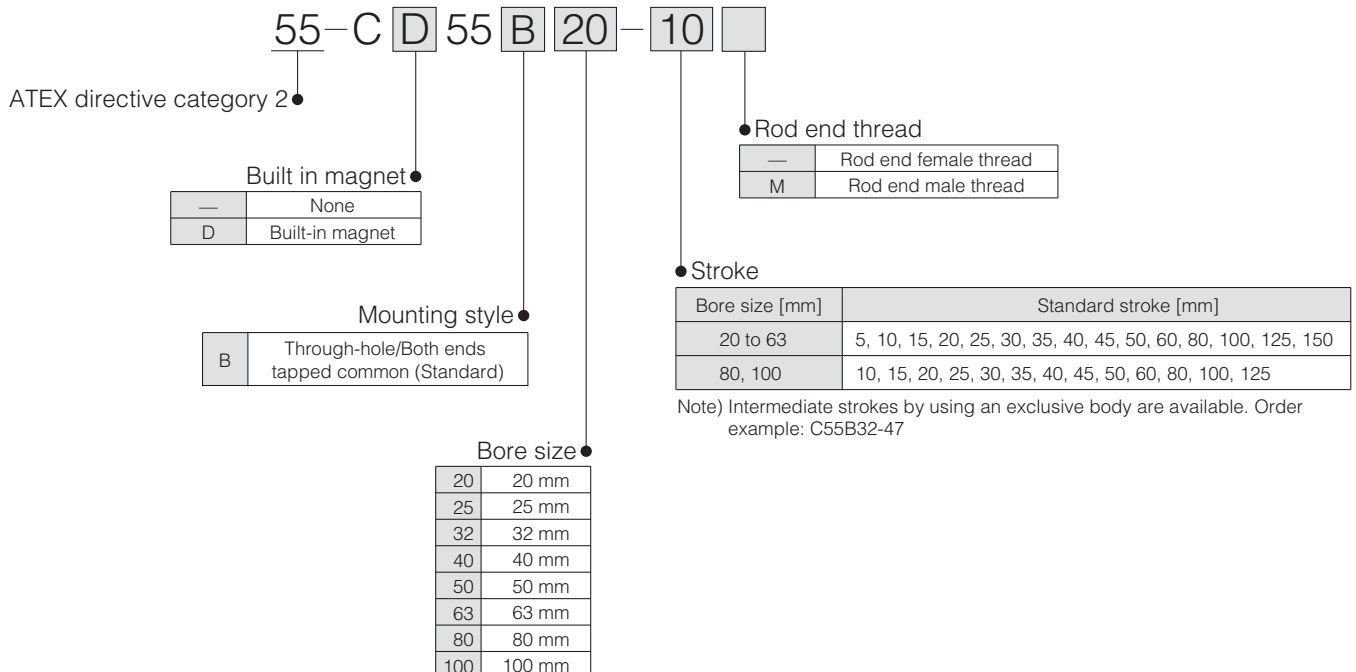

C55 - Accesories/Related Products

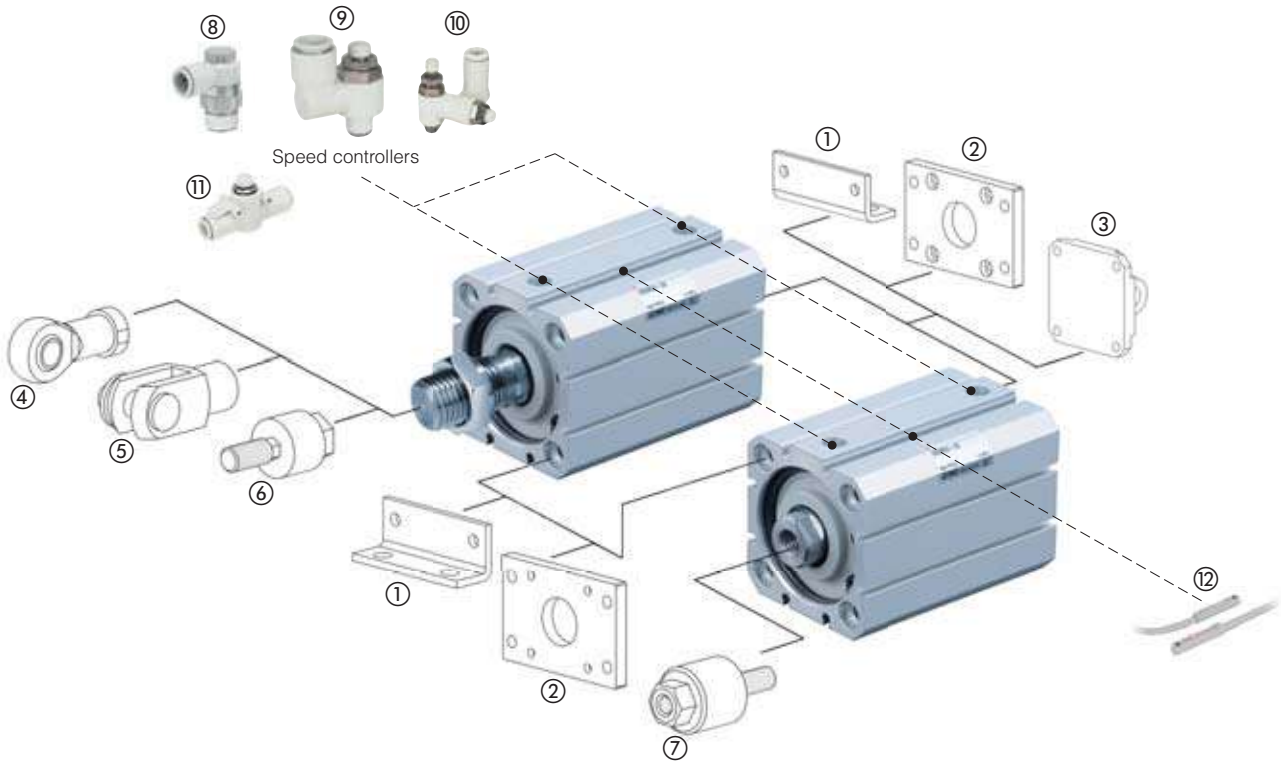

Bore size [mm]	①	②	③	④	⑤	⑥	⑦
	Foot (Supplied with 2 pieces and 4 screws)	Flange (Supplied with 4 screws)	Single clevis (Supplied with 4 screws)	Piston rod ball joint (ISO8139)	Rod clevis (ISO8140) (Supplied with bolt and safety device)	Floating joint for male thread	Floating joint for female thread
20	C55-L020	C55-F020	C55-C020	KJ8D	GKM8-16	JA20-8-125	JB25-6-100
25	C55-L025	C55-F025	C55-C025	KJ8D	GKM8-16	JA20-8-125	JB25-6-100
32	C55-L032	C55-F032	C55-C032	KJ10D	GKM10-20	JA30-10-125	JB40-8-125
40	C55-L040	C55-F040	C55-C040	KJ10D	GKM10-20	JA30-10-125	JB40-8-125
50	C55-L050	C55-F050	C55-C050	KJ12D	GKM12-24	JA40-12-125	JB63-10-150
63	C55-L063	C55-F063	C55-C063	KJ12D	GKM12-24	JA40-12-125	JB63-10-150
80	C55-L080	C55-F080	C55-C080	KJ16D	GKM16-32	JA50-16-150	-
100	C55-L100	C55-F100	C55-C100	KJ16D	GKM16-32	JA50-16-150	-

Bore size [mm]	⑧		⑨		⑩	
	Speed controller elbow type		Speed controller universal type		Dual speed controller	
	∅ tube	Part number	∅ tube	Part number	∅ tube	Part number
20, 25	3.2	AS1201F-M5-23A	3.2	AS1301F-M5-23	3.2	-
	4	AS1201F-M5-04A	4	AS1301F-M5-04	4	ASD230F-M5-04
	6	AS1201F-M5-06A	6	AS1301F-M5-06	6	ASD230F-M5-06
32, 40	3.2	AS2201F-01-23A	3.2	AS2301F-01-23	3.2	-
	4	AS2201F-01-04SA	4	AS2301F-01-04S	4	-
	6	AS2201F-01-06SA	6	AS2301F-01-06S	6	ASD330F-01-06S
	8	AS2201F-01-08SA	8	AS2301F-01-08S	8	ASD330F-01-08S
10	AS2201F-01-10SA	10		10		
50, 63 80, 100	-	-	-	-	-	-

Bore size [mm]	⑪	
	∅ tube	Part number
20	3.2	AS1002F-23
	4	AS2002F-04
	6	AS2052F-06
	8	AS2052F-08
25, 32	4	AS2002F-04
	6	AS2052F-06
	8	AS2052F-08
40, 50	6	AS3002F-06
	8	AS3002F-08
	10	AS3002F-10
	12	AS3002F-12
63	6	AS3002F-06
	8	AS3002F-08
	10	AS4002F-10
	12	AS4002F-12
80, 100	10	AS4002F-10
	12	AS4002F-12

⑫		
Auto switch		
Solid state type - 2 colour indication		
Part No.	Wiring	Cable
D-M9BWL	2 wire	3 m
D-M9PWL	3 wire PNP	3 m
D-M9PWSAPC	M8-3pin PNP	0.5 m
For ATEX ^{Note)}		
D-M9BWL-588	2 wire	3 m
D-M9PWL-588	3 wire PNP	3 m
D-M9PWSAPC-588	M8-3pin PNP	0.5 m
Reed type		
Part No.	Wiring	Cable
D-A93L	2 wire	3 m
D-A93SAPC	M8-3pin	0.5 m
For ATEX ^{Note)}		
D-A93L-588	2 wire	3 m
D-A93SAPC-588	M8-3pin	0.5 m

Note) When mounting an auto switch on a 55-series (Category 2) model, the ATEX class of the cylinder with auto switch changes to Category 3, which is the same class as the auto switch. Auto switch only conforms to Category 3. (II 3GD EEx nA II T5x -10 °C ≤ Ta ≤ +60 °C IP67)

More Related Products

More Related Products

Series KQ2 - Fittings

- Easy and quick assembly with less labour costs and high flexibility



Series GUM/GUL - Guide Units

- External guides for cylinders with bores from 12 to 100



Series SY - 5 Port Solenoid Valves

- Unique all-purpose solenoid valve
- Up to 125 bore cylinders
- Outsanding flow while compact
- Plug-in metal base type available



Series AR - Regulator

- Port sizes from M5 to 1" and set pressure range from 0.05 to 0.85 MPa



Small auto switch mountable on all types

Perfect for use with our easy to set 2-colour indication solid state auto switch, series D-M9W



A **green** light illuminates up at the optimum operating range.

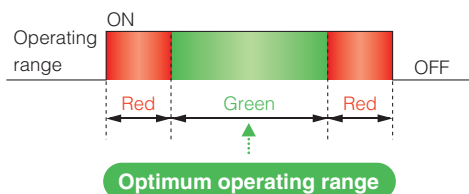

Series TU - Tubing

- Good flexibility and available in 29 different colours



Series VBA - Booster Regulator

- Increase factory air pressure by up to 4 times



Series VFS - 5 Port Solenoid Valves

- For big bore cylinders
- Up to 300 bore cylinders



Series IR - Precision Regulator

- For instrumentation applications with a selectable pressure range from 0.005 to 0.8 MPa



Series RB - Shock Absorbers

- Wide range and automatic adjustment to the most appropriate absorption performance



Series AV - Soft Start-up Valve

- Gradually increases supply pressure during start up and rapidly exhausts air when the supply air is shut off



Series SY/SYJ - 3 Port Solenoid Valves

- Suitable to operate single acting cylinders
- High flow with low power consumption



Series ITV - Electro-Pneumatic Regulator

- Stepless control of air pressure proportional to an electrical signal with set pressure range from 0.005 to 0.9 MPa

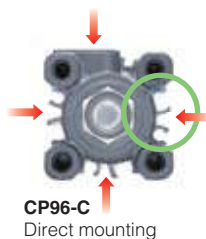

Other non-ISO cylinders

Other non-ISO cylinders that may suit your needs

Series CG1-Z Round cylinder



The Most Flexible Round Cylinder

When you need a round cylinder with many options...

- Shorter and cleaner than equivalent tie-rod cylinder
- Female and male rod end thread
- Grease for food processing equipment
- PTFE grease
- Non-rotating Rod
- Direct mount
- Direct mount / Non-rotating Rod
- Low friction
- With end lock
- With one-touch fittings
- Air-hydro type
- Clean series
- Copper free
- Water resistant

Bores: Ø 20, Ø 25, Ø 32, Ø 40, Ø 50, Ø 63, Ø 80, Ø 100

Standard strokes: from 25 to 300 mm (Maximum stroke up to 1500 mm)

Series CG3 Round cylinder. Short type



The Most Compact Round Cylinder

If space, weight or cleanliness is a challenge...

- Space saving
- Light weight
- Clean profile
- Female and male rod end thread

Bores: Ø 20, Ø 25, Ø 32, Ø 40, Ø 50, Ø 63, Ø 80, Ø 100

Standard strokes: from 25 to 300 mm

Series CG5-S Stainless Steel Round cylinder



The Cleanest Round Cylinder

For use in environments with water splashing such as food processing machines...

- Special scraper as standard prevents water from entering the cylinder
- All external parts (including mounts) are made from Stainless Steel (SUS304)
- Two types of seal material NBR or FKM can be selected
- Extended service life as it can be disassembled for replacement of seals

Bores: Ø 20, Ø 25, Ø 32, Ø 40, Ø 50, Ø 63, Ø 80, Ø 100

Standard strokes: from 25 to 300 mm (Maximum stroke up to 1500 mm)

Series CQ2-Z Compact cylinder



The Most Flexible Compact Cylinder

If you need the special to be standard...

- Female and male rod end thread
- Non-rotating Rod
- Axial Piping
- Anti-lateral Load
- With end lock
- Water Resistant
- Smooth Cylinder
- Low-speed
- Heat resistant cylinder (-10~150 °C)
- Cold resistant cylinder (-40~70 °C)
- With heavy duty scraper
- Piston rod, rod end nut made of SUS
- With coil scraper
- Fluoro rubber for seals
- Dual stroke cylinder / Double rod type
- Dual stroke cylinder / Single rod type
- Change of rod end shape
- With boss in rod side
- With concave boss on head end
- Special port location
- With one-touch fittings
- Air-hydro type
- Clean series
- Copper and fluorine-free series

Bores: Ø 12, Ø 16, Ø 20, Ø 25, Ø 32, Ø 40, Ø 50, Ø 63, Ø 80, Ø 100, Ø 125, Ø 140, Ø 160, Ø 180, Ø 200

Standard strokes: from 5 to 300 mm

Series CQU Compact cylinder. Plate type



The Thinnest Compact Cylinder

When you have tried everything and nothing else fit in that small space...

- Light and compact
- Allows smaller mounting pitch
- Female and male rod end thread

Bores: Ø 20, Ø 25, Ø 32, Ø 40

Standard strokes: from 5 to 100 mm

Series MGP-Z Compact Guide Cylinder



The Most Flexible and Compact Guide Cylinder

If you need the robustness of a guide cylinder...

- Slide bearing type
- Ball bushing type
- High precision ball bushing type
- Wide type (for transferring large work pieces)
- Copper and fluorine-free series
- Change of guide rod end shape
- Low-speed
- Machining tapped hole, drilled hole and pin hole additionally
- Bottom mounting style
- Symmetrical port position
- Lateral piping type
- Heat resistant cylinder (-10~150 °C)
- Fluoro rubber for seals
- With air cushion
- With end lock
- Heavy duty guide rod
- With lock
- Clean series
- Water Resistant
- With shock absorber
- With heavy duty scraper
- With parts made of SUS
- Extension/retraction adjustable type
- With coil scraper
- Dust proof type
- With felt

Bores: Ø 12, Ø 16, Ø 20, Ø 25, Ø 32, Ø 40, Ø 50, Ø 63, Ø 80, Ø 100

Standard strokes: from 10 to 400 mm

- **Digital catalogue:** www.smc.eu
 - Select the product you need
 - Validate the part number
 - Get the required information
 - PDF documentation
 - 3D CAD
 - Technical information
 - Stock information



- **Cylinder Configurator:** www.smc.eu
 - Download the Cylinder Configurator
 - Install it or execute it
 - Select the cylinder series
 - Configure the cylinder and accessories
 - Contact SMC

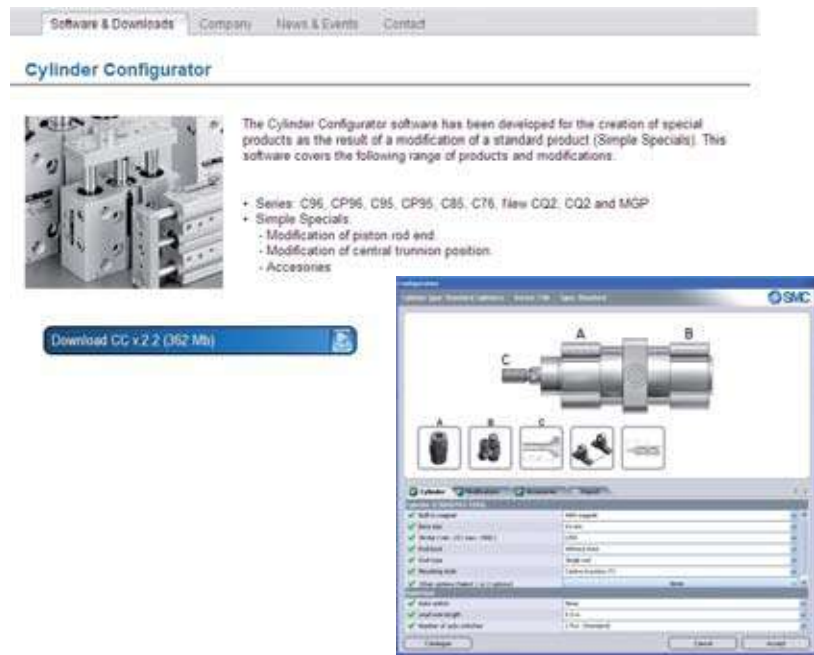

SMC CORPORATION (Europe)

Austria	+43 (0)2262622800	www.smc.at	office@smc.at	Lithuania	+370 5 2308118	www.smclt.lt	info@smclt.lt
Belgium	+32 (0)33551464	www.smc-pneumatics.be	info@smc-pneumatics.be	Netherlands	+31 (0)205318888	www.smc-pneumatics.nl	info@smc-pneumatics.nl
Bulgaria	+359 (0)2807670	www.smc.bg	office@smc.bg	Norway	+47 67129020	www.smc-norge.no	post@smc-norge.no
Croatia	+385 (0)13707288	www.smc.hr	office@smc.hr	Poland	+48 222119600	www.smc.pl	office@smc.pl
Czech Republic	+420 541424611	www.smc.cz	office@smc.cz	Portugal	+351 226166570	www.smc.eu	postpt@smc.smces.es
Denmark	+45 70252900	www.smc.dk.com	smc@smc.dk.com	Romania	+40 213205111	www.smcromania.ro	smcromania@smcromania.ro
Estonia	+372 6510370	www.smc-pneumatics.ee	smc@smc-pneumatics.ee	Russia	+7 8127185445	www.smc-pneumatik.ru	info@smc-pneumatik.ru
Finland	+358 207513513	www.smc.fi	smc@smc.fi	Slovakia	+421 (0)413213212	www.smc.sk	office@smc.sk
France	+33 (0)164761000	www.smc-france.fr	info@smc-france.fr	Slovenia	+386 (0)73885412	www.smc.si	office@smc.si
Germany	+49 (0)61034020	www.smc.de	info@smc.de	Spain	+34 902184100	www.smc.eu	post@smc.smces.es
Greece	+30 210 2717265	www.smc-hellas.gr	sales@smc-hellas.gr	Sweden	+46 (0)86031200	www.smc.nu	post@smc.nu
Hungary	+36 23511390	www.smc.hu	office@smc.hu	Switzerland	+41 (0)523963131	www.smc.ch	info@smc.ch
Ireland	+353 (0)14039000	www.smc-pneumatics.ie	sales@smc-pneumatics.ie	Turkey	+90 212 489 0 440	www.smc-pneumatik.com.tr	info@smc-pneumatik.com.tr
Italy	+39 0292711	www.smc-italia.it	mailbox@smc-italia.it	UK	+44 (0)845 121 5122	www.smc-pneumatics.co.uk	sales@smc-pneumatics.co.uk
Latvia	+371 67817700	www.smc.lv	info@smc.lv				

ISOCTYL-01B-UK